

Section A-A
Pin 1,5,9

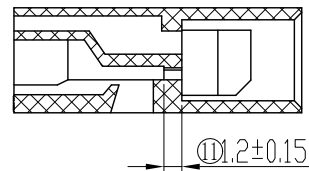

Section B-B
Pin 2,3,4,6,7,8

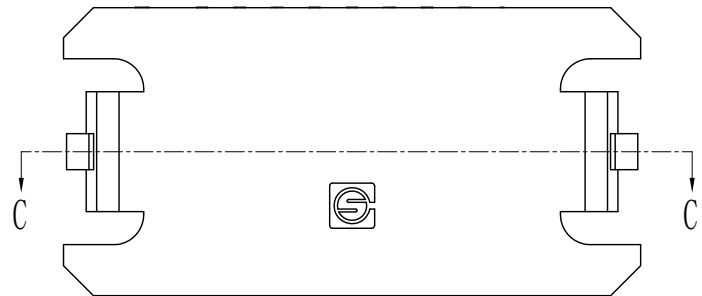

Section C-C

Unless otherwise specified tolerance:

X.	±0.50	X.°	±3°
.X	±0.38	.X°	±2°
.XX	±0.25		

Performance characteristics:

1. Main body part material
Insulator: PA66, Black UL94V-0
2. Electrical requirements:
Current rating: 3 A
Voltage rating: 250 V
Insulation resistance: $\geq 1000 \text{ M}\Omega$
Withstanding voltage: 1000 Vr.m.s., 1mA, 60s
3. Mechanical requirements
Insertion force: $\leq 40\text{N}$ (9pin)
Extraction force: 4.5N~50N(9pin)
(mating female housing:13431125, mating female terminal:13433035)
Terminal retention force: $\geq 10\text{N}$ (terminal:13433034)
4. Environment specification
Working temperature: $-40^\circ\text{C} \sim +105^\circ\text{C}$
Humidity: $\leq 93\%$ at 40°C
5. Packing & storing
Method of packing: plastic bag, inner box, outer box
Storing condition: temperature of $-10^\circ\text{C} \sim +40^\circ\text{C}$
below 80% relative humidity
6. Style of installation: crimp cable installation
7. To prevent the pollution of the environment product info
RoHS agreement: In line with the European Union RoHS.

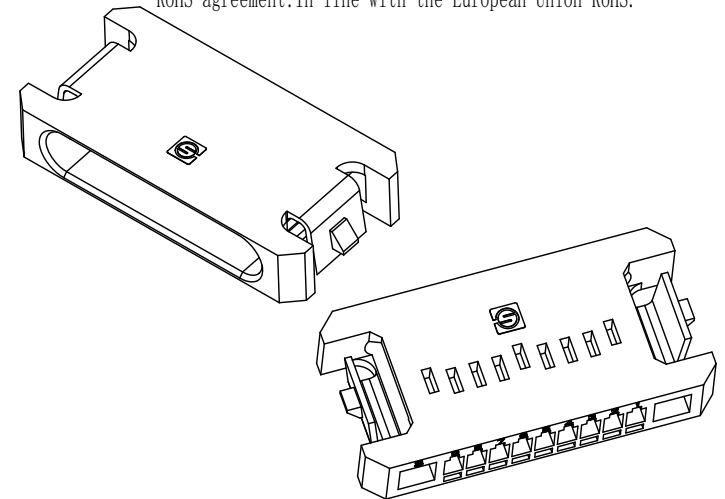

①	1	502370	Change Yu	2021.04.29
Mark	NO.	File NO.	Signature	Date
DRAW			Change Yu	2020.04.20
CHK			Tim	2021.05.31
MAN				
STD			Juanli lia	2021.06.01
APP			Alan	2021.06.01

2.50mm Pitch Wafer
Male Housing 9 Pin

13431126

SL0.1343.021

Projection	Rev.	Weight	Scale
	B1		
All Dimensions in mm		Sheet 1 of 1	
SHINNING SHENZHEN SHINNING ELECTRONIC CO.LTD.			