

N= Number of contacts

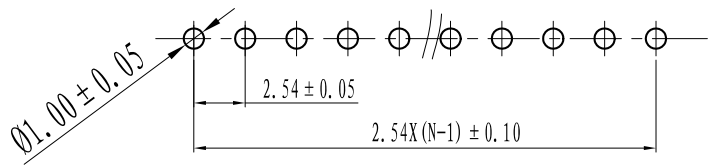

PCB LAYOUT

- Performance characteristics:
- Main body part material
Insulator: see spec list
Contact terminal: brass, 1.27μm Ni under plated, outer plating see spec list
 - Electrical requirements:
Current rating: 3 A
Contact resistance: ≤20 mΩ
Insulation resistance: ≥5000 MΩ
Withstanding voltage: 1000 Vr.m.s, 1ma, 60s
 - Mechanical requirements
Retention: ≥10 N/pin
 - Environment specification
Working temperature: -55°C ~ +125°C
Humidity: <93% at 40°C
Resistance to soldering heat: 245°C±5°C, 10s (PBT insulator)
260°C±5°C, 10s (PPS, PA6T & LCP insulator)
 - Packing & storing
Method of packing: plastic bag, inner box, outer box
Storing condition: temperature of -10°C ~ +40°C
below 80% relative humidity
 - Style of installation: solder pcb installation
 - To prevent the pollution of the environment product info
RoHS agreement: In line with the European Union RoHS.

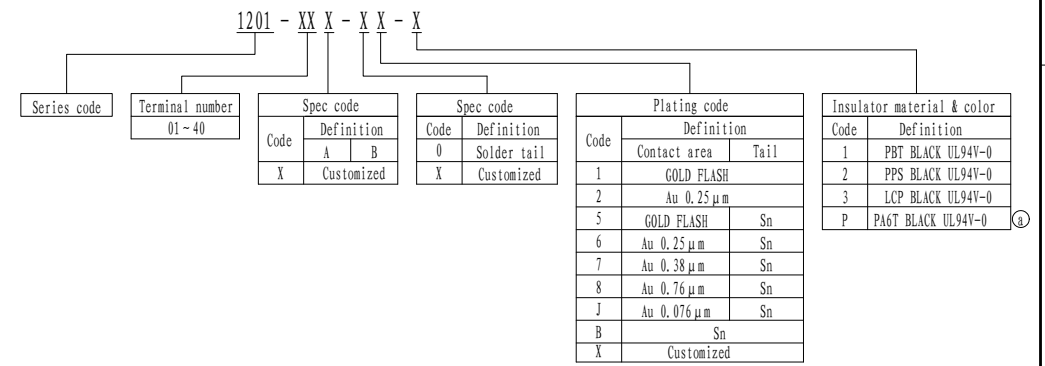

Unless otherwise specified tolerance:

X.	±0.50	X.°	±3°
.X	±0.38	.X°	±2°
.XX	±0.25		

⑥	1	387686	Xiaowei Pan	2019.05.20
⑦	1	342752	Xiaowei Pan	2018.10.17
⑧	1	330736	Xiaowei Pan	2018.08.24
Mark	NO.	File NO.	Signature	Date
DRAW			LinZhao	2014.04.17
CHK			Tim	2019.5.25
MAN			Emily	2019.5.27
STD			Alan	2019.5.27
APP				

2.54mm pitch single row terminal strips straight pin

SL0.1201.100

Projection	Rev.	Weight	Scale
	B7		

All Dimensions in mm Sheet 1 of 2

SHINNING SHENZHEN SHINNING ELECTRONIC CO.LTD.

The 7th spec code:

	Code	A	B	P/N
Ⓔ	0	11.00	3.00	1201-XX0-0X-X
	1	11.60	3.20	1201-XX1-0X-X
	2	22.00	3.20	1201-XX2-0X-X
	3	17.00	3.50	1201-XX3-0X-X
	4	10.90	2.50	1201-XX4-0X-X
	6	17.60	3.00	1201-XX6-0X-X
	7	8.90	3.80	1201-XX7-0X-X
	8	12.20	3.90	1201-XX8-0X-X
	9	13.80	3.20	1201-XX9-0X-X
Ⓖ	A	9.50	7.00	1201-XXA-0X-X
	B	13.80	3.80	1201-XXB-0X-X
	C	13.80	6.00	1201-XXC-0X-X
	D	22.00	3.50	1201-XXD-0X-X
	E	13.46	2.79	1201-XXE-0X-X
	H	7.50	3.00	1201-XXH-0X-X
	G	21.08	2.79	1201-XXG-0X-X
	K	11.60	3.00	1201-XXK-0X-X
Ⓕ	N	11.00	2.70	1201-XXN-0X-X
	P	8.70	2.50	1201-XXP-0X-X
	Q	9.10	3.40	1201-XXQ-0X-X
	R	14.0	3.00	1201-XXR-0X-X
	S	11.60	2.20	1201-XXS-0X-X
Ⓑ	T	11.54	3.00	1201-XXT-0X-X
	W	17.00	3.00	1201-XXW-0X-X
	U	15.00	3.20	1201-XXU-0X-X
	J	23.70	3.20	1201-XXJ-0X-X
Ⓒ	F	12.60	3.30	1201-XXF-0X-X
Ⓓ	M	10.00	3.00	1201-XXM-0X-X

Ⓔ	1	387686	Xiaowei Pan	2019.05.20	2.54mm pitch single row terminal strips straight pin	SL0.1201.100			
Ⓕ	1	342752	Xiaowei Pan	2018.10.17		Projection	Rev.	Weight	Scale
Ⓒ	1	330736	Xiaowei Pan	2018.08.24			B7		
Mark	NO.	File NO.	Signature	Date		All Dimensions in mm Sheet 2 of 2			
DRAW	LinZhao 2014.04.17				1201-XXX-XX-X	SHINNING SHENZHEN SHINNING ELECTRONIC CO.,LTD.			
CHK	Tim2019.5.25								
MAN									
STD	Emily2019.5.27								
APP	Alan2019.5.27								