

3D VIEW (S=1:1)

Performance characteristics:

1. Main body part material
Insulator: PA6(F1) BLACK UL94 V-0
Contact terminal: N/A
2. Electrical requirements:
Current rating: N/A
Voltage rating: N/A
Contact resistance: N/A
Insulation resistance: N/A
Withstanding voltage: N/A
3. Mechanical requirements
Insertion force: N/A
Extraction force: N/A
Mechanical life: 50 cycles
Wire gauge: adapter cable outer diameter 5~9mm
Cable retention force: 100N MIN
4. Environment specification
Working temperature: -40°C~+85°C
5. Applicable standard: N/A
6. Packing & storing
Method of packing: Tray , inner box, outer box
Storing condition: temperature of -10°C~+40°C
below 80% relative humidity
7. Style of installation: cable installation.
8. To prevent the pollution of the environment product info
RoHS agreement: In line with the european union RoHS

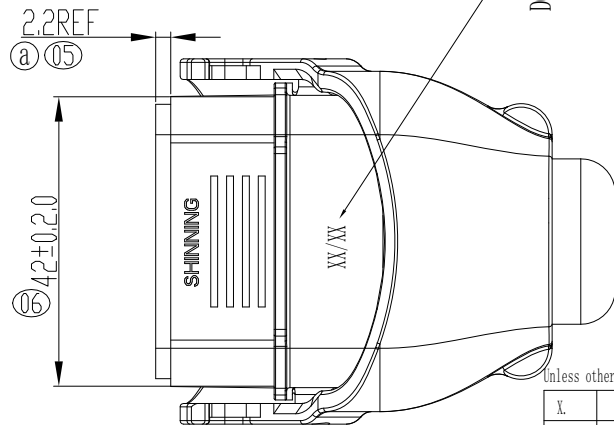
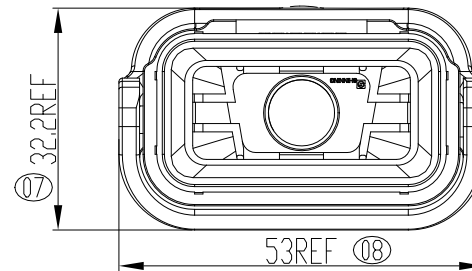
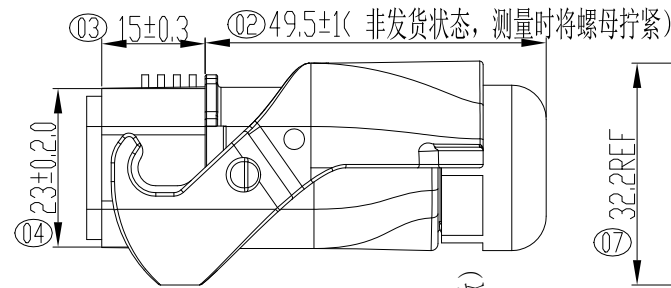
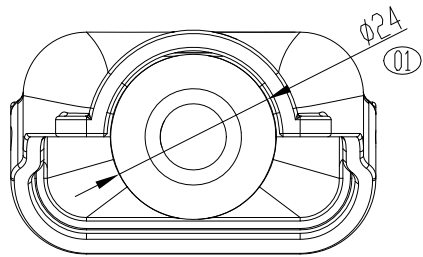

Unless otherwise specified tolerance:

X.	±0.50	X.°	±3°
.X	±0.38	.X°	±2°
.XX	±0.25		

①	1	494958	xudongbin	2021.03.23
Mark	NO.	File NO.	Signature	Date
DRAW	XUDONGBIN 2019.10.15			
CHK	Lawrence 20201.04.14			
MAN				
STD	Juanli lai 2021.04.19			
APP	Alan2021.04.19			

1450 QDB15 WATERPROOF CAP		SL0.1450.007	
Projection	Rev.	Weight	Scale
	A1		
14506002(14060772)		Sheet 1 of 1	

All Dimensions in mm			
SHINNING SHENZHEN SHINNING ELECTRONIC CO.,LTD.			